



MAX7057 Evaluation Kit

General Description

The MAX7057 evaluation kit (EV kit) provides a proven design to evaluate the MAX7057 frequency-programmable ASK/FSK transmitter in a 16-pin SO package. The EV kit uses Windows XP®, Windows Vista®, and Windows® 7-compatible software to provide a simple graphical user interface (GUI). The EV kit enables testing of the device's RF performance and requires no additional support circuitry. The RF output uses a 50Ω matching network and an SMA connector for convenient connection to test equipment. The EV kit PCB comes with a MAX7057ASE+ installed on the EV kit.

Features

- ◆ Windows XP-, Windows Vista-, and Windows 7-Compatible Software
- ◆ USB Powered
- ◆ Proven PCB Layout
- ◆ Proven Components List
- ◆ Adjustable Programmable Frequency
- ◆ Fully Assembled and Tested

Ordering Information

PART	TYPE
MAX7057EVKIT+	EV Kit

+Denotes lead(Pb)-free and RoHS compliant.

Component List

DESIGNATION	QTY	DESCRIPTION
BATT-2032	0	Not installed, battery holder and contact solution Battery Holders BA2032
BATT-AAA	0	Not installed, plastic battery holder Keystone 2468
C1, C9, C12	3	220pF ±5%, 50V C0G ceramic capacitors (0402) Murata GRM1535C1H221J
C2, C8, C13	3	0.01µF ±10%, 50V X7R ceramic capacitors (0402) Murata GRM155R71H103K
C3, C6, C14	3	0.1µF ±10%, 16V X7R ceramic capacitors (0402) TDK C1005X7R1C104K
C5, C11, C15, C16, C17, C20, C21, C22, C58, C60, C68, C70, C71, C72	14	0.1µF ±10%, 16V X7R ceramic capacitors (0603) Murata GRM188R71C104K
C7	1	220pF ±5%, 50V C0G ceramic capacitor (0603) Murata GRM1885C1H221K
C10, C39, C62, C63	4	10pF ±5%, 50V C0G ceramic capacitors (0603) Murata GRM1885C1H100J

DESIGNATION	QTY	DESCRIPTION
C18, C23, C65, C67	4	10µF ±10%, 6.3V X5R ceramic capacitors (0805) Murata GRM188R60J106M
C19, C24, C64, C66	4	1µF ±10%, 16V X5R ceramic capacitors (0603) Murata GRM188R61C105K
C31, C32, C59, C61	4	100pF ±5%, 50V C0G ceramic capacitors (0603) Murata GRM1885C1H101J
C33, C34	2	3.9pF ±0.25pF, 50V C0G ceramic capacitors (0603) Murata GRM1885C1H3R9C
C36	1	680pF ±5%, 50V C0G ceramic capacitor (0603) Murata GRM1555C1H681J
C38	1	6.8pF ±0.5pF, 50V C0G ceramic capacitor (0603) Murata GRM1885C1H6R8D
C69	1	33nF ±10%, 16V X7R ceramic capacitor (0603) Murata GRM188R71C333K
C73, C74	2	22pF ±5%, 50V C0G ceramic capacitors (0603) Murata GRM1885C1H220J

Windows, Windows XP, and Windows Vista are registered trademarks of Microsoft Corp.



MAX7057 Evaluation Kit

Evaluates: MAX7057

Component List (continued)

DESIGNATION	QTY	DESCRIPTION
C75	0	Not installed, ceramic capacitor (0603)
D1–D6	6	Yellow LEDs (1206)
D7–D12	6	Green LEDs (1206)
GND–A–GND–F, P1.7, VADJ, VDUT–A, VDUT–B, VEXT, 3V3	12	1-pin headers
J1	1	8-pin (2 x 4) header
J2	1	6-pin (2 x 3) header
J3, J4	0	Not installed, 40-pin (2 x 20) headers
JU1–JU9, JU31–JU34	13	3-pin headers
JU10, JU11	2	2-pin headers
JU12	1	36-pin (2 x 18) header
L1	1	13nH ±5% (0603) Murata LQW18AN13NJ00
L2	1	22nH ±5% (0603) Murata LQW18AN22NJ10
P1	1	USB type-B right-angle female receptacle
Q1	1	Dual n-channel FET (6 SuperSOT) Fairchild FDC6301N
R1, R7, R8, RB	4	0Ω ±5% resistors (0603)
R2, R44, R45, RA	0	Not installed, resistors (0603)
R3, R50–R54, R56	7	100Ω ±5% resistors (0603)
R4, R6, R14, R22, R23, R36, R38, R46, R47	9	150Ω ±5% resistors (0603)
R11, R19, R20, R21, R24–R27, R33, R34	10	100kΩ ±1% resistors (0603)
R13	1	59kΩ ±1% resistor (0603)
R15	1	158kΩ ±1% resistor (0603)
R18	1	43Ω ±5% resistor (0603)
R30	1	50kΩ ±10% potentiometer Vishay TS63Y503k
R31	1	27.4kΩ ±1% resistor (0603)
R32	1	39.2kΩ ±1% resistor (0603)

DESIGNATION	QTY	DESCRIPTION
R35	1	75Ω ±5% resistor (0603)
R37	1	330Ω ±5% resistor (0603)
R40, R41	2	27Ω ±5% resistors (0603)
R42	1	470Ω ±1% resistor (0603)
R43	1	1.5kΩ ±5% resistor (0603)
REFIN	0	Not installed, SMA female vertical connector
RFOUT	1	SMA female vertical connector
S1, S2	2	Momentary pushbutton switches
S3	1	Quad SPST DIP switch (normally open)
TP15, TP21–TP25, TP27	7	Red miniature test points
TP29, TP36, TP38, TP40	4	Red multipurpose test points
TP30–TP35, TP37, TP39, TP41	9	Black multipurpose test points
U1	1	300MHz to 450MHz frequency-programmable ASK/FSK transmitter (16 SO) Maxim MAX7057ASE+
U2	1	32-bit microcontroller (68 QFN–EP*) Maxim MAXQ2000–RAX+
U3, U4, U9, U12	4	Low-noise LDO linear regulators (5 SC70) Maxim MAX8512EXK+
U5	0	Not installed, 93C46 3-wire EEPROM (8 SO)
U6	1	UART-to-USB converter (32 TQFP)
U7, U8, U10, U11	4	8-channel level translators (20 TSSOP) Maxim MAX3001EEUP+
Y1	1	16MHz crystal Crystek 017466
Y2	0	Not installed, 32.768kHz crystal

*EP = Exposed pad.

MAX7057 Evaluation Kit

Evaluates: MAX7057

Component List (continued)

DESIGNATION	QTY	DESCRIPTION
Y3	1	16MHz crystal Hong Kong X'tals SSM1600000E18FAF
Y4	1	6MHz crystal (HCM49) Hong Kong X'tals SSL600000018FAF

DESIGNATION	QTY	DESCRIPTION
—	33	Shunts
—	1	USB high-speed A-to-B cables, 6ft
—	1	PCB: MAX7057 EVALUATION KIT+

Component Suppliers

SUPPLIER	PHONE	WEBSITE
Crystek Corporation	800-237-3061	www.crystek.com
Fairchild Semiconductor	888-522-5372	www.fairchildsemi.com
Hong Kong X'tals Ltd.	852-35112388	www.hongkongcrystal.com
Murata Electronics North America, Inc.	770-436-1300	www.murata-northamerica.com
TDK Corp.	847-803-6100	www.component.tdk.com
Vishay	203-268-6261	www.vishay.com

Note: Indicate that you are using the MAX7057 when contacting these component suppliers.

MAX7057 EV Kit Files

FILE	DESCRIPTION
INSTALL.EXE	Installs the EV kit files on your computer
MAX7057.EXE	Application program
CDM20600.EXE	Installs the USB device driver
UNINSTALL.EXE	Uninstalls the EV kit software
USB_Driver_Help_200.PDF	USB driver installation help file
MAX7057_CONSOLE.EXE	Advanced user interface application
MAX7057.DLL	Required for the advanced user interface
CMODCOMM.DLL	Required for the advanced user interface

MAX7057 Evaluation Kit

Quick Start

Required Equipment

- MAX7057 EV kit
- Windows XP, Windows Vista, or Windows 7 PC with a spare USB port
- Spectrum analyzer

Note: In the following sections, software-related items are identified by bolding. Text in **bold** refers to items directly from the EV kit software. Text in **bold and underlined** refers to items from the Windows operating system.

Procedure

The EV kit is fully assembled and tested. Follow the steps below to verify board operation:

- 1) Visit www.maxim-ic.com/evkitsoftware to download the latest version of the EV kit software, 7057Rxx.ZIP. Save the EV kit software to a temporary folder and uncompress the ZIP file.
- 2) Install the EV kit software and USB driver on your computer by running the INSTALL.EXE program inside the temporary folder. The program files are copied to your PC and icons are created in the Windows **Start | Programs** menu. During software installation, some versions of Windows may show a warning message indicating that this software is from an unknown publisher. This is not an error condition and it is safe to proceed with installation. Administrator privileges are required to install the USB device driver on Windows.
- 3) Verify that all jumpers are in their default positions, as shown in Table 1.
- 4) Connect the USB cable from the PC to the EV kit board. A Windows message appears when connecting the EV kit board to the PC for the first time. Each version of Windows has a slightly different message. If you see a Windows message indicating **ready to use**, then proceed to the next step. Otherwise, open the USB_Driver_Help_200.PDF document in the Windows **Start | Programs** menu to verify that the USB driver was installed successfully.
- 5) Start the EV kit software by opening its icon in the **Start | Programs** menu. The EV kit software main window appears, as shown in Figure 1.
- 6) Connect the RFOUT SMA connector to the spectrum analyzer. Set the analyzer to a center frequency of 315MHz and a span of 4MHz.
- 7) The EV kit GUI indicates that the digital USB hardware is connected in the lower-left status bar and the lower-right status bar indicates that the IC is connected.
- 8) The IC operates in ASK mode by default. Set the IC's ASK frequency to 315MHz by typing **315** in the **Frequency** edit box inside the **Low Frequency (0x04, 0x05)** group box. Press enter to set the frequency.
- 9) Click on the **ENABLE (0x08)** checkbox in the **ENABLE** group box.
- 10) Click on the **DATAIN (0x07)** checkbox in the **DATAIN** group box to set it to 1.
- 11) The spectrum analyzer should display a peak of approximately +10dBm at 315MHz. Set **DATAIN** to 0 by clicking its checkbox. The spectrum analyzer peak at 315MHz should be gone. Set **DATAIN** to 1 by clicking its checkbox. The center frequency is again at 315MHz.
- 12) To test FSK, first uncheck the **ENABLE (0x08)** checkbox. Click on the **mode** checkbox in the **CONTROL (0x00)** group box to set FSK. The **FSK** and **High Frequency (0x02, 0x03)** group boxes become active. In the **FSK** group box, set the center frequency to 315MHz and the frequency deviation to $\pm 50\text{kHz}$ (default). The **High Frequency** and **Low Frequency** automatically set based on the entries in the **FSK** group box.
- 13) Click on the **ENABLE (0x08)** checkbox.
- 14) When **DATAIN** is 0, the low frequency is the carrier frequency in the spectrum analyzer. When **DATAIN** is 1, the high frequency is the carrier frequency in the spectrum analyzer. Toggle **DATAIN** and observe the frequency shift on the spectrum analyzer for the low and high values.

Additional Evaluation:

- 15) For efficiency measurements, take the shunt off pins 9-10 of jumper JU12 and place an ammeter between pins 9-10 on JU12. Set VDD to 2.7V by adjusting R30.
- 16) Connect a power meter to RFOUT. Measure the output power and supply current.
- 17) The total efficiency is calculated by the following equation:

$$\text{Efficiency} = \frac{10^{(P_{\text{OUT}}/10)}}{I \times V}$$

For example, if P_{OUT} is equal to +9.2dBm, the supply current is 12.2mA, the supply voltage is 2.7V, and the efficiency is approximately 25%.

MAX7057 Evaluation Kit

Evaluates: MAX7057

Table 1. Control Side Jumper Table (J1, JU1–JU12)

JUMPER	SHUNT POSITION	DESCRIPTION
J1	1-2	VDUT (IC) powered by the battery.
	3-4	VDUT powered by the USB. Do not use this setting for the IC.
	5-6	VDUT powered by an external supply. Apply the external voltage between the VEXT and GND_ test points.
	7-8*	VDUT powered by an adjustable on-board regulator. Change the resistance on potentiometer R30 to the required DUT supply.
JU1	1-2	Connects the external supply to the REG supply.
	2-3*	Connects the USB supply to the REG supply.
JU2	1-2*	Microcontroller supply comes from the REG supply.
	2-3	Microcontroller supply comes from the battery. Installation of battery holders is required.
JU3	1-2*	Selects the AAA battery holder for the VBAT supply.
	2-3	Selects the 2032 battery holder for the VBAT supply.
JU4	1-2	Sets the core microcontroller supply (VMICRO) to VLO (2V typ).
	2-3*	Sets the core microcontroller supply (VMICRO) to 2.5V.
JU5	1-2*	Sets the logic microcontroller supply (VMICROL) to 3.3V.
	2-3	Sets the logic microcontroller supply (VMICROL) to VMICRO.
JU6	1-2	Reserved for future use.
	2-3*	Connects the microcontroller oscillator to the on-board crystal.
JU7	1-2	Reserved for future use.
	2-3*	Connects the microcontroller oscillator to the on-board crystal.
JU8	1-2	Reserved for future use.
	2-3*	Connects the RTC oscillator to the on-board crystal (not installed).
JU9	1-2	Reserved for future use.
	2-3*	Connects the RTC oscillator to the on-board crystal (not installed).
JU10	Closed	GPO2 connects to the DUT through level translators.
	Open*	GPO2 does not connect to the DUT.
JU11	Closed*	GPO1 connects to the DUT GPO through level translators.
	Open	GPO1 does not connect to the DUT.
JU12	Closed*	See Table 2.

*Default position.

MAX7057 Evaluation Kit

Evaluates: MAX7057

Table 2. JU12 Jumper Table

JU12 PINS	SHUNT POSITION	DESCRIPTION
1-2	Closed*	Don't care.
3-4	Closed*	Don't care.
5-6	Closed*	Don't care.
7-8	Closed*	Don't care.
9-10	Closed*	VDD supply on the IC side is powered by the VDUT supply on the control side.
	Open	Externally power the VDD supply on the IC side by applying a voltage between the VDD test point (TP29) and the GND test point (TP31). Only open for current measurements (see step 15 in the <i>Additional Evaluation</i> section).
11-12	Closed*	Connects the GPO signal from the IC to the on-board microcontroller. The GPO signal can be monitored on TP15.
	Open	The GPO signal is not connected to the on-board microcontroller. The GPO signal can be monitored by an external microcontroller on the GPO test point TP15 without interference loading from the on-board microcontroller.
13-14	Closed*	Don't care.
15-16	Closed*	Don't care.
17-18	Closed*	Don't care.
19-20	Closed*	Don't care.
21-22	Closed*	Don't care.
23-24	Closed*	Connects the on-board \overline{CS} to the IC. \overline{CS} can be monitored on TP21.
	Open	Does not connect the on-board \overline{CS} to the IC. When using external SPI™, remove this jumper and apply the \overline{CS} signal to TP21.
25-26	Closed*	Connects the on-board SDI to the IC. SDI can be monitored on TP22.
	Open	Does not connect the on-board SDI to the IC. When using external SPI, remove this jumper and apply the SDI signal to TP22.
27-28	Closed*	Connects the on-board SCLK to the IC. SCLK can be monitored on TP23.
	Open	Does not connect the on-board SCLK to the IC. When using external SPI, remove this jumper and apply the SCLK signal to TP23.
29-30	Closed*	Connects the on-board enable signal (EN) to the IC. EN can be monitored on TP24.
	Open	Does not connect the on-board EN signal to the IC. When using an external signal for enable, remove this jumper and apply the EN signal to TP24.
31-32	Closed*	Connects the on-board transmitter data signal (DIN) to the IC. DIN can be monitored on TP25.
	Open	Does not connect the on-board transmitter data signal to the IC. When using an external signal for transmitter data remove this jumper and apply the DIN signal to TP25.
33-34	Closed*	Don't care.
35-36	Closed*	Connects the microcontroller to the on-board SDO from the IC. SDO can be monitored on TP27. SDO has shared functionality with GPO.
	Open	Does not connect the microcontroller to the SDO signal from the IC. When using external SPI, remove this jumper and connect TP27 to the MISO input.

*Default position.

SPI is a trademark of Motorola, Inc.

MAX7057 Evaluation Kit

Table 3. DUT Side Jumper Table (JU31–JU34)

JUMPER	SHUNT POSITION	DESCRIPTION
JU31	1-2*	Connects DVDD to VDD.
	2-3	Connects DVDD to TP37. Must apply an external voltage between TP36 and TP37 (GND) to power DVDD.
JU32	1-2	Connects AVDD to TP38. Must apply an external voltage between TP38 and TP39 (GND) to power AVDD.
	2-3*	Connects AVDD to VDD.
JU33	1-2	Connects PAVDD to TP40. Must apply an external voltage between TP40 and TP41 (GND) to power PAVDD.
	2-3*	Connects PAVDD to VDD.
JU34	1-2	Connects PAOUT to ROUT for ASK amplitude shaping in.
	2-3*	Connects PAOUT to PAVDD for ASK amplitude shaping out.

*Default position.

Layout Issues

A properly designed PCB is essential for any RF/micro-wave circuit. Keep high-frequency input and output lines as short as possible to minimize losses and radiation. At high frequencies, trace lengths that are on the order of $\lambda/10$ or longer can act as antennas.

Both parasitic inductance and capacitance are influential on circuit layouts and are best avoided by using short trace lengths. Generally, a 10-mil wide PCB trace 0.0625in above a ground plane with FR4 dielectric has about 19nH/in of inductance and about 1pF/in of capacitance. In the matching network, where the inductor is on the order of 22nH and a capacitor is on the order of 10pF, the proximity of the circuit to the IC has a strong influence on the effective component values.

To reduce the parasitic inductance, use a solid ground or power plane below the signal traces. Also, use low-inductance connections to ground on all GND pins, and place decoupling capacitors close to all VDD connections.

Detailed Description of Software

The main window of the MAX7057 EV kit is shown in Figure 1.

Main Control Tab

The EV kit GUI is grouped by register addresses. Actions on the GUI perform write and read operations. Reads are automatically done after each write for verification. GPO is configured to SDO every time a read operation is

done. GPO is set back to the user setting after the read operation.

DATAIN and ENABLE

The **DATAIN** and **ENABLE** registers each have a single bit that is ORed with a hardware control pin on the EV kit board. Clicking on the checkbox writes to the respective register bit (software control). Pressing the **HW EN** or **HW DIN** buttons on the GUI sends a digital control signal from the on-board microcontroller to the respective inputs on the IC (hardware control). For example, the **ENABLE (0x08)** checkbox represents the enable bit found in register 0x08. A digital control signal from the on-board microcontroller connects to the IC enable input and can be toggled by pressing the **HW EN** button. If using software control, drive the **ENABLE** input low and control the enable function by pressing the **ENABLE (0x08)** checkbox. To control the enable feature by hardware, keep the **ENABLE (0x08)** checkbox unchecked. **DATAIN** works similarly with the **HW DIN** input.

Applying an External Signal

To apply an external signal to **ENABLE** or **DATAIN**, the respective jumper must first be removed and the signal applied to the signal test point. For example, to apply an external signal to DIN, first uncheck the **DATAIN (0x08)** checkbox. Then remove the jumper from pins 31-32 of JU12 and apply the DIN signal to TP24. A complex pattern can be sent using the transmitter in this fashion. **ENABLE** works similarly.

MAX7057 Evaluation Kit

ASK Carrier Frequency Programming

To program the carrier frequency in ASK mode, enter the carrier frequency in megahertz in the **Frequency** edit box inside the **Low Frequency (0x04, 0x05)** group box. Only the low-frequency registers are used for programming the carrier frequency for ASK. The GUI greys the **High Frequency (0x02, 0x03)** group box and the **FSK** group box when ASK is selected. Every time the carrier frequency is changed, the FLOAD bit is written to without user intervention. The carrier frequency has a range-limited delta-sigma modulator. When the carrier frequency is outside that range, a label inside the group box indicates that the frequency is out of range.

FSK Carrier Frequency Programming

There are two ways to program the carrier frequencies in FSK mode. One method is to program the **High Frequency** and **Low Frequency** by typing in the values in the **Frequency** edit boxes. Every time the high and low frequencies change, the FLOAD bit is written without user intervention.

FSK Group Box

The **FSK** group box allows an easy way to program the high and low frequencies when operating in FSK mode. Enter the center frequency in MHz and the frequency deviation in kHz. The center frequency and deviation must be within the proper range of operation.

Registers Tab

The EV kit **Registers** tab (Figure 2) displays each register's individual bit logic-level status. A data bit in bold indicates a logic-high, while a data bit not bolded indicates a logic-low. Clicking on the individual data bit toggles the bit and performs a write command. The new command is shown in the edit box at the right. Write commands can be written to the registers alternatively by typing a hex value in the edit box and pressing the Enter key on the keyboard.

Advanced User Interface

A console application is available for advanced users by clicking **Options | Interface (Advanced Users)** (Figure 3).

The console application offers an alternative method to programming the IC. Every string on the console is a command.

Detailed Description of Hardware

The MAX7057 EV kit provides a proven layout for the IC. On-board test points are included to monitor various signals (Table 4).

Power Supply

The IC operates from a 2.1V to 3.6V supply. The EV kit has several options to power off of the USB, or the user can externally supply a voltage to the control side or the DUT side. To power off of the USB supply, change the shunt on J1 on the control side. The shunt is in the 7-8 position by default. That position makes VDUT equal to VADJ. The user can monitor VADJ with a voltmeter and change potentiometer R30 resistance to adjust the voltage between a 2.1V to 3.6V range. **Do not put the shunt on J1 in the 3-4 position because that sets VDUT equal to VBUS (5V), which exceeds the allowable supply voltage.** The 1-2 position on J1 allows the VDUT to be powered from a battery. Battery holders (not populated) are required.

External Voltage

To apply an external voltage to the IC, the voltage must be applied on the control side between VEXT and GND-. The shunt on jumper JU1 must be in the 5-6 position.

Table 4. DUT-Side Signal Test Points

TEST POINT	NAME	DESCRIPTION
TP15	GPO	GPO can act as the SDO for SPI communication or various other outputs. Use TP27 for SDO in SPI.
TP21	\overline{CS}	Chip-select for SPI.
TP22	SDI	Serial data in for SPI.
TP23	SCLK	Serial clock for SPI.
TP24	EN	Hardware enable for the IC.
TP25	DIN	Hardware transmitter data for the IC.
TP27	GPO	Serial data out for SPI.

MAX7057 Evaluation Kit

Evaluates: MAX7057

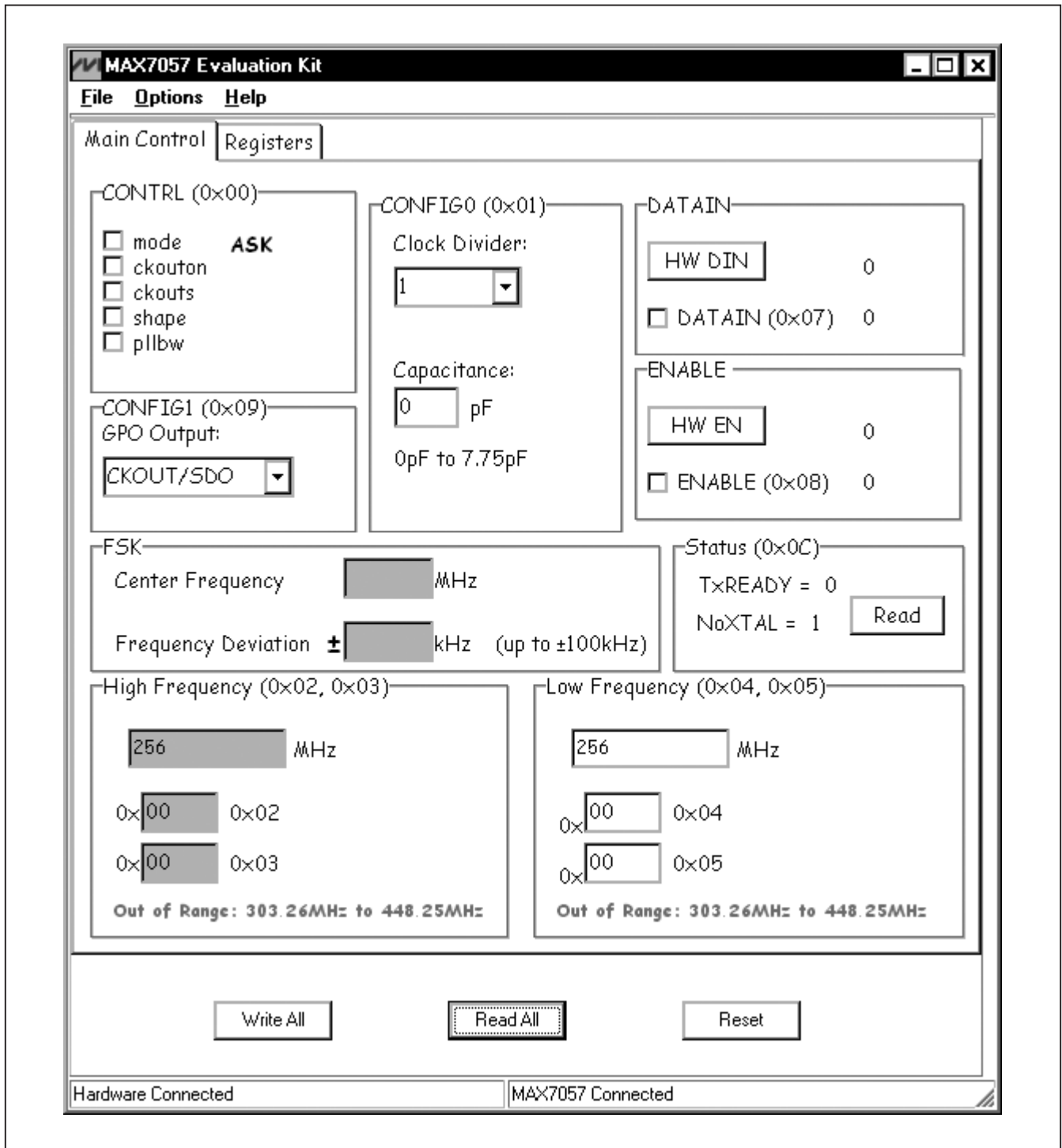

Figure 1. MAX7057 EV Kit Software Main Control Panel

MAX7057 Evaluation Kit

Evaluates: MAX7057

	B7	B6	B5	B4	B3	B2	B1	B0	
CONTRL Addr = 0x00	0	0	0	pllbw	shape	ckouts	ckouton	mode	00
CONFIG0 Addr = 0x01	ckdiv2	ckdiv1	ckdiv0	cap4	cap3	cap2	cap1	cap0	00
HIFREQ1 Addr = 0x02	fhi15	fhi14	fhi13	fhi12	fhi11	fhi10	fhi9	fhi8	00
HIFREQ0 Addr = 0x03	fhi7	fhi6	fhi5	fhi4	fhi3	fhi2	fhi1	fhi0	00
LOFREQ1 Addr = 0x04	flo15	flo14	flo13	flo12	flo11	flo10	flo9	flo8	00
LOFREQ0 Addr = 0x05	flo7	flo6	flo5	flo4	flo3	flo2	flo1	flo0	00
FLOAD Addr = 0x06	0	0	0	0	0	0	0	fload	00
DATAIN Addr = 0x07	0	0	0	0	0	0	0	data_in	00
EN Addr = 0x08	0	0	0	0	0	0	0	enable	00
CONFIG1 Addr = 0x09	0	0	0	0	0	gpose2	gpose1	gpose0	00
STATUS Addr = 0x0C	fhi/lo15	fhi/lo14	fhi/lo13	fhi/lo12	X	0	TxRdy	NoXtal	09

High Frequency out of Range
Low Frequency out of Range

Hardware Connected MAX7057 Connected

Figure 2. MAX7057 EV Kit Software Registers Panel

MAX7057 Evaluation Kit

Evaluates: MAX7057

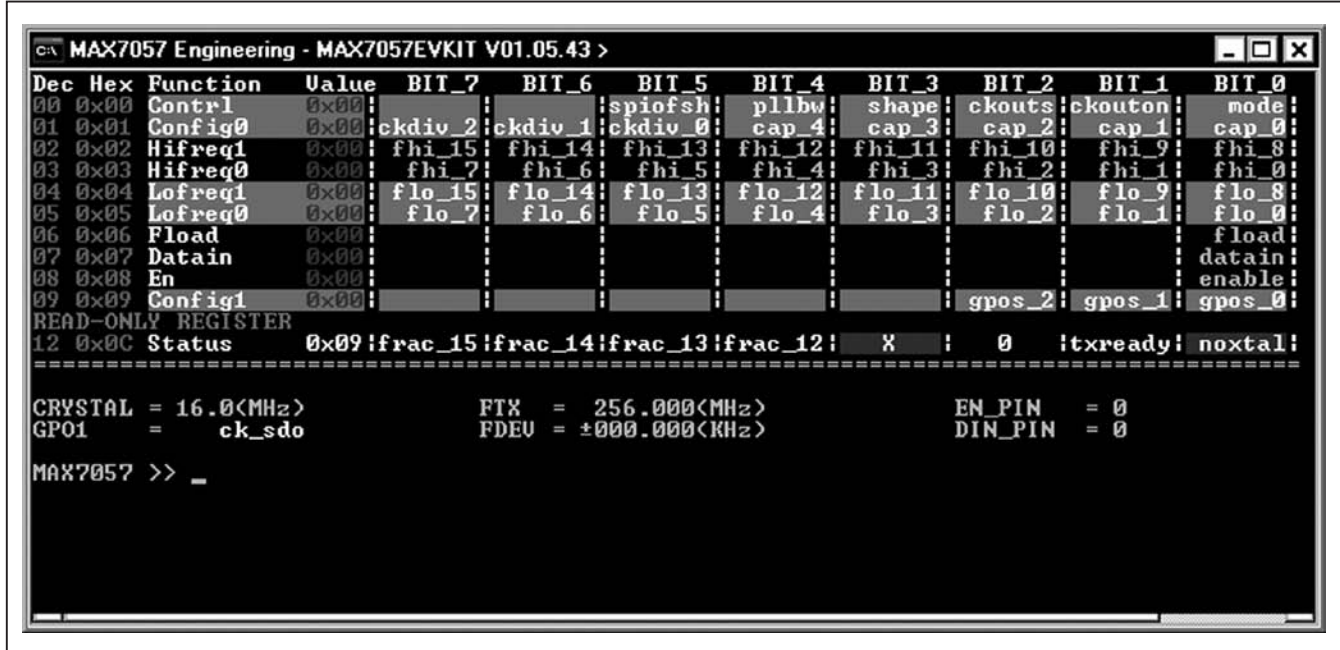

Figure 3. Advanced User Interface Window (Console Application)

AVDD and PAVDD

AVDD and PAVDD are powered by VDD by default. To apply an external voltage to AVDD, change the shunt on jumper JU32 to the 1-2 position and apply an external voltage on TP38. To apply an external voltage to PAVDD, change the shunt on jumper JU33 to the 1-2 position and apply an external voltage on TP40.

Table 5. SPI Jumpers and Test Points

JU12 PINS	TEST POINT	NAME
23-24	TP15	\overline{CS}
25-26	TP21	SDI
27-28	TP22	SCLK
35-36	TP23	GPO

External SPI

Remove the shunts from the SPI jumpers and apply the signals to the SPI test points. The SPI jumpers are located on jumper JU12. See Table 5 for descriptions.

External Frequency Input

For applications where an external frequency is desired over the crystal frequency, it is possible to apply an external frequency through REFIN. Resistor R2 is necessary (use 0Ω). The EV kit GUI assumes the crystal frequency is always 16MHz. Use the **Advanced User Interface** for different crystal frequencies.

MAX7057 Evaluation Kit

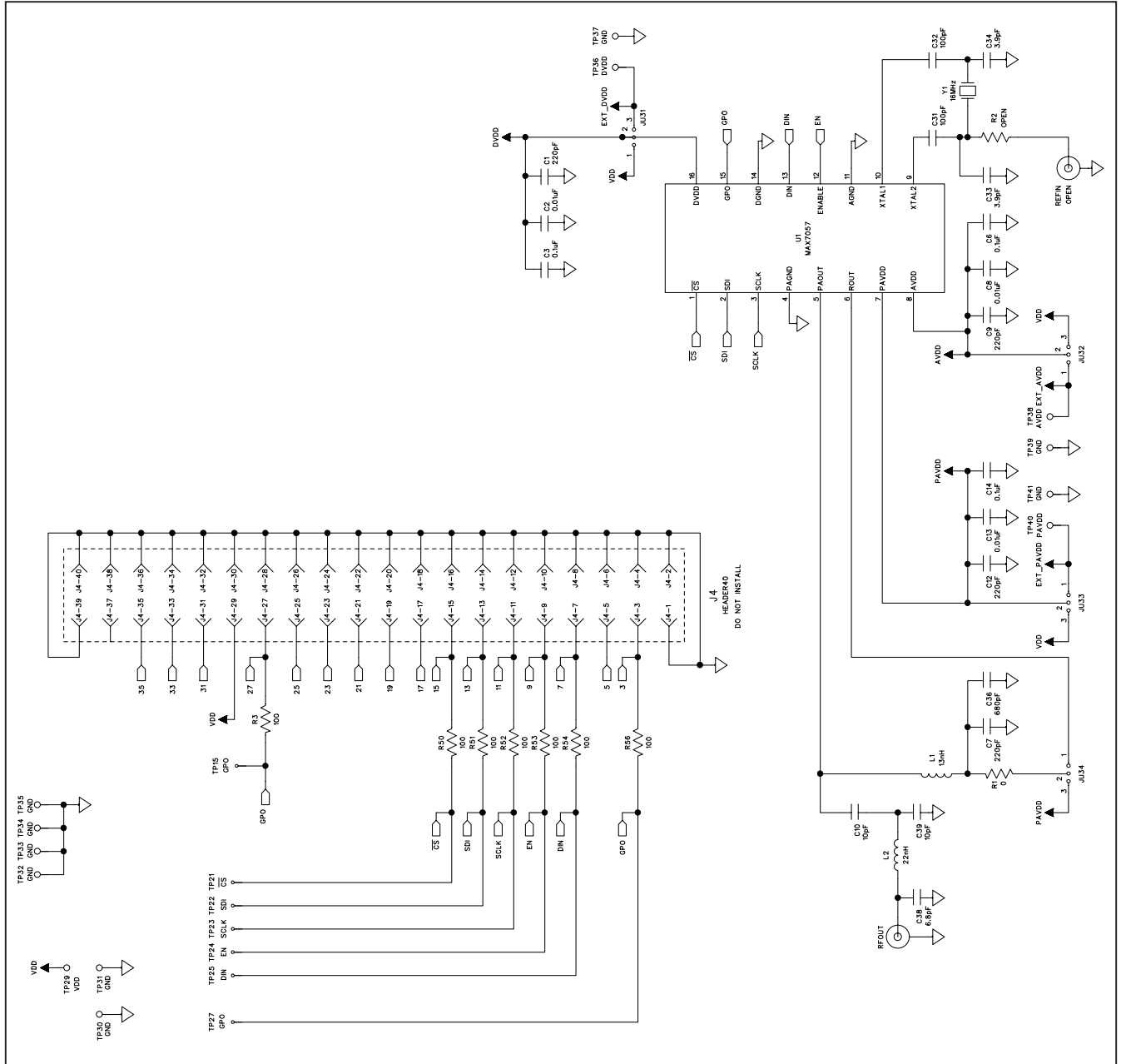

Figure 4a. MAX7057 EV Kit Schematic (Sheet 1 of 5)

MAX7057 Evaluation Kit

Evaluates: MAX7057

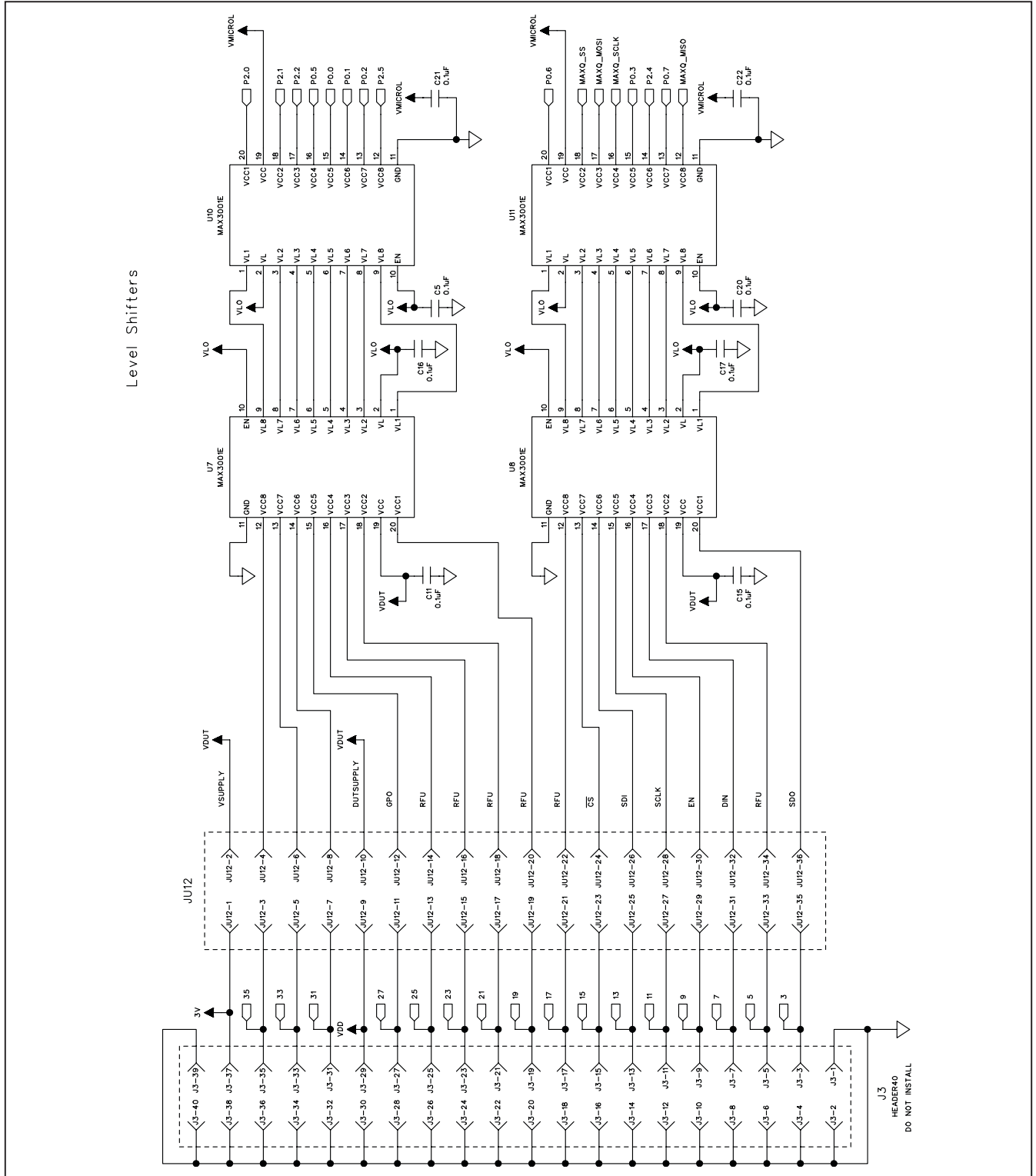

Figure 4b. MAX7057 EV Kit Schematic (Sheet 2 of 5)

MAX7057 Evaluation Kit

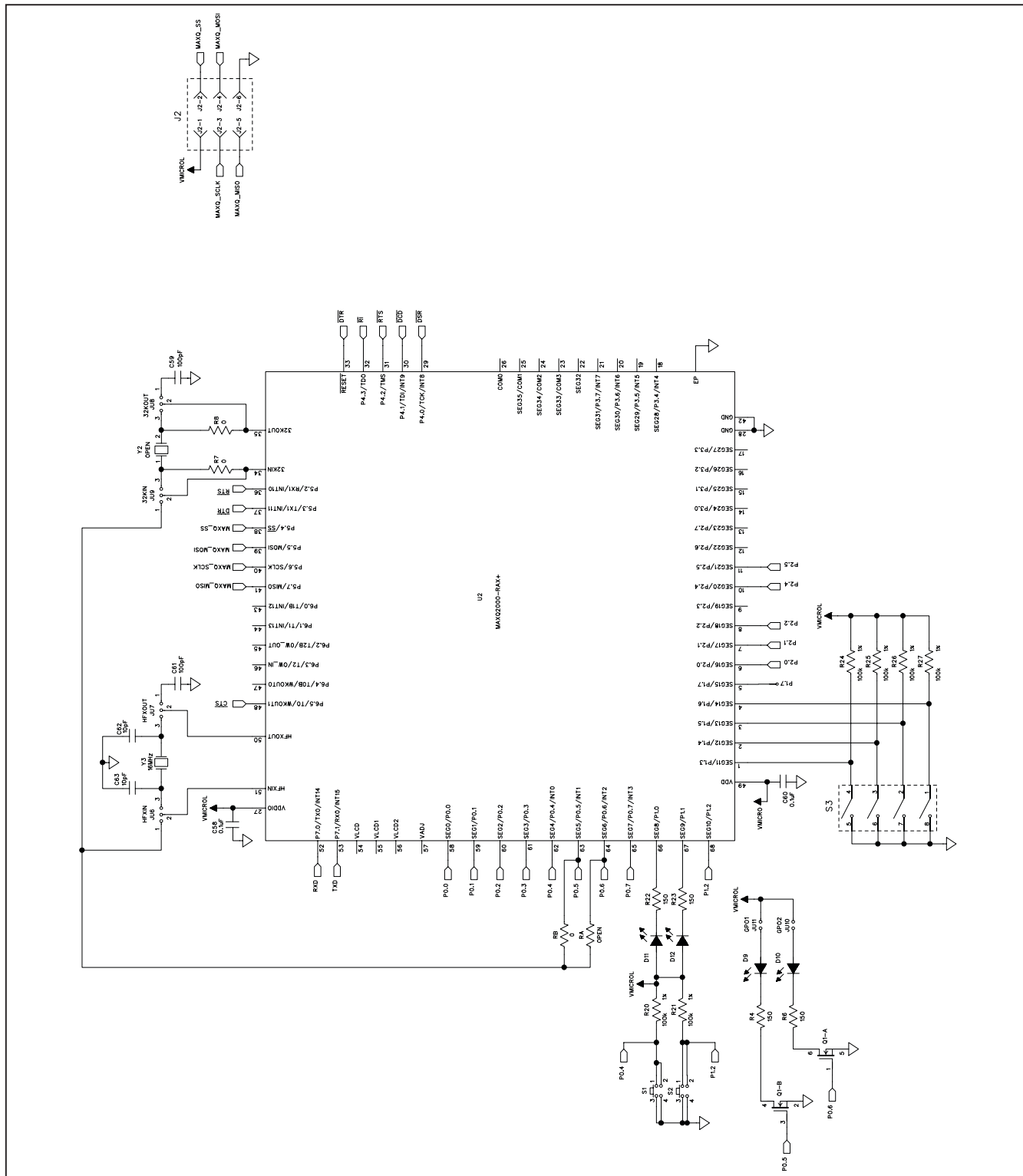

Figure 4c. MAX7057 EV Kit Schematic (Sheet 3 of 5)

MAX7057 Evaluation Kit

Evaluates: **MAX7057**

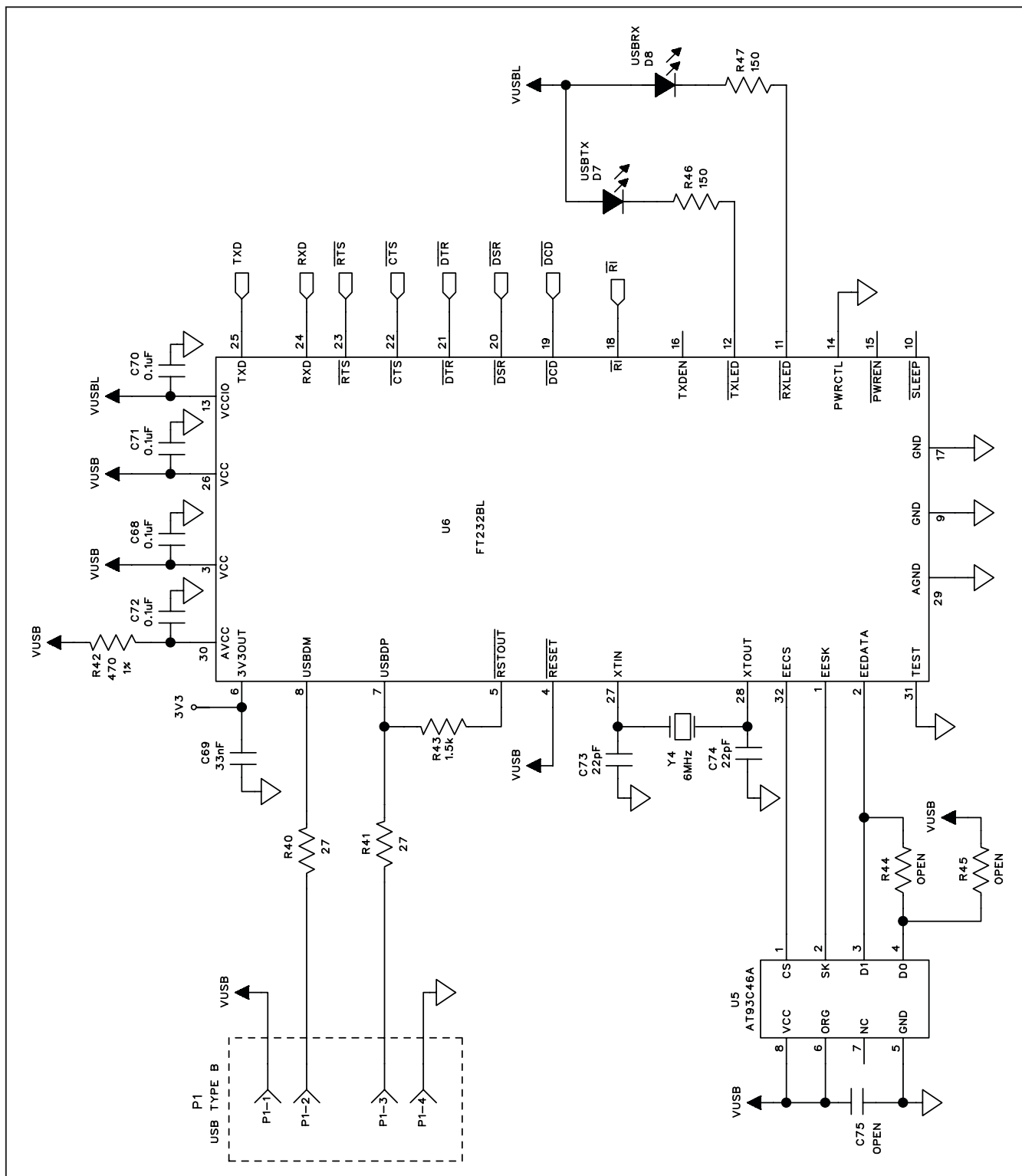

Figure 4d. MAX7057 EV Kit Schematic (Sheet 4 of 5)

MAX7057 Evaluation Kit

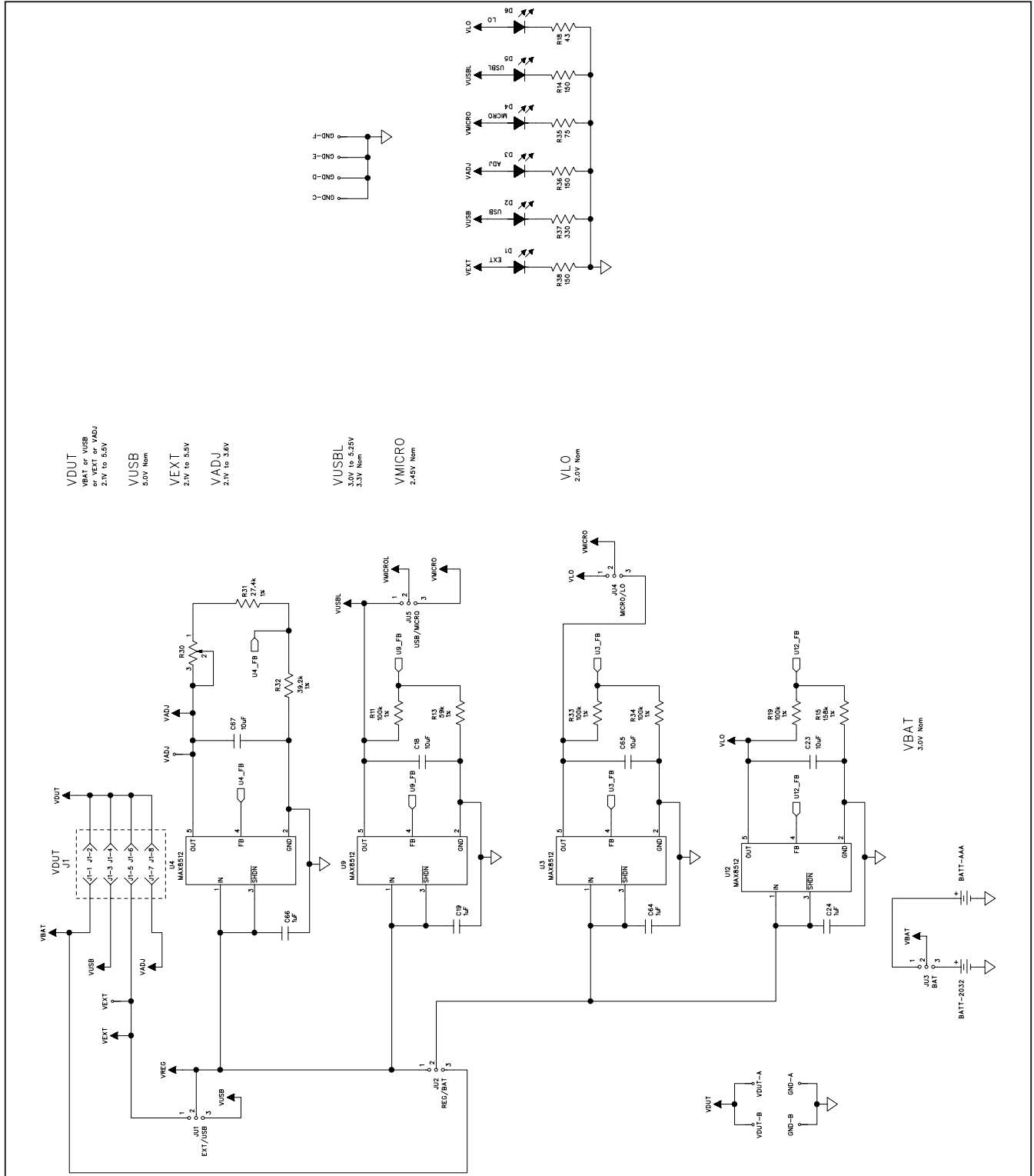

Figure 4e. MAX7057 EV Kit Schematic (Sheet 5 of 5)

MAX7057 Evaluation Kit

Evaluates: MAX7057

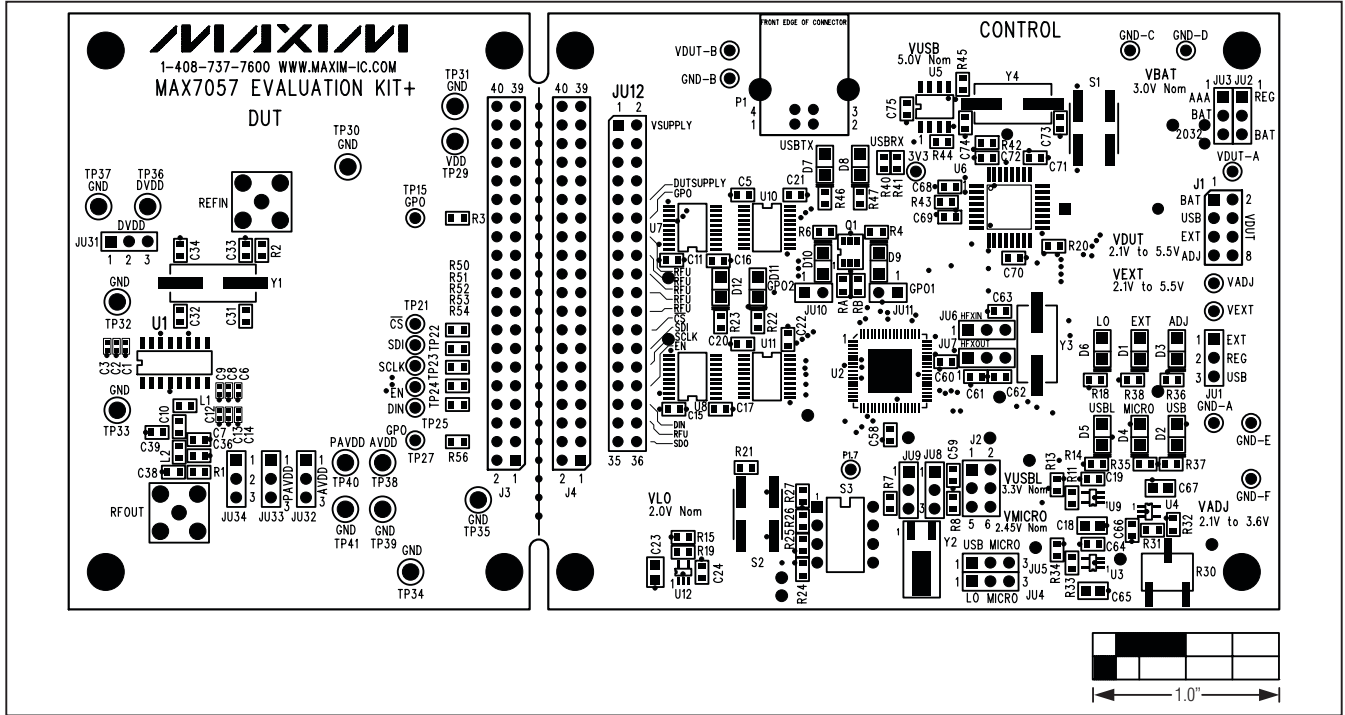

Figure 5. MAX7057 EV Kit Component Placement Guide—Component Side

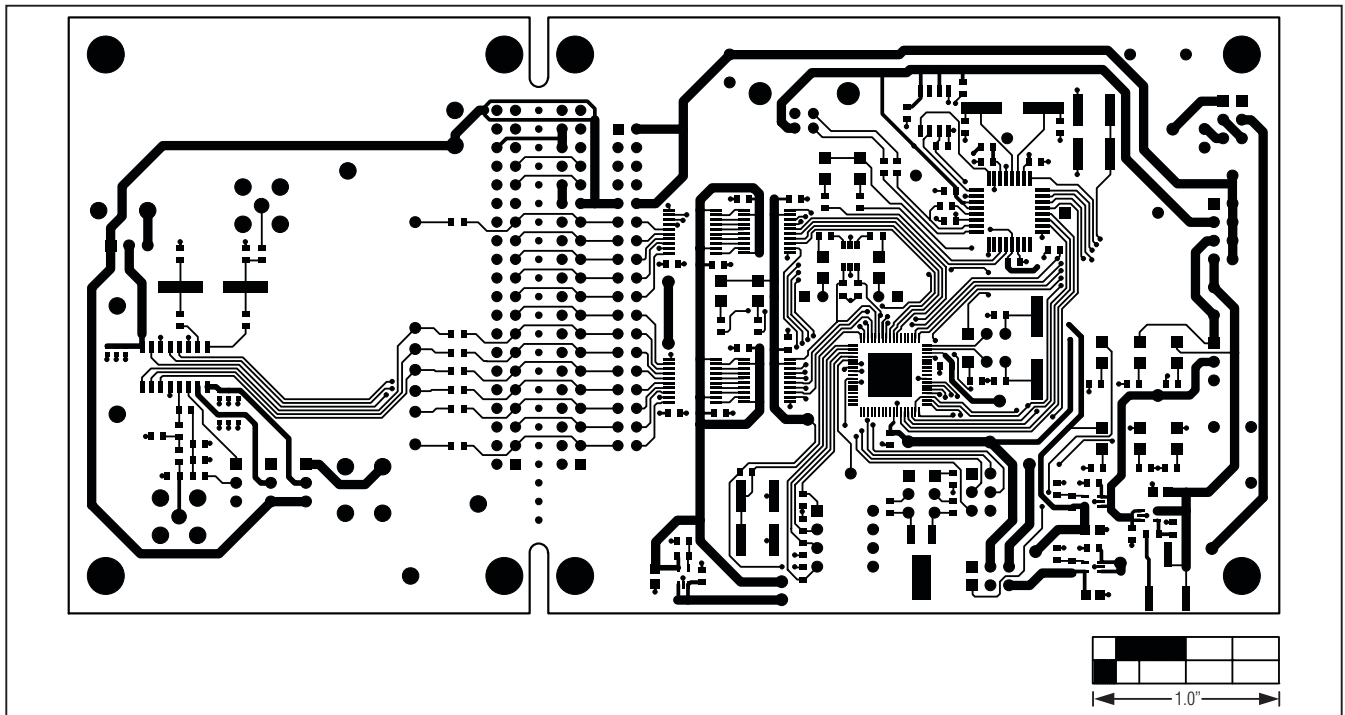

Figure 6. MAX7057 EV Kit PCB Layout—Component Side

MAX7057 Evaluation Kit

Evaluates: MAX7057

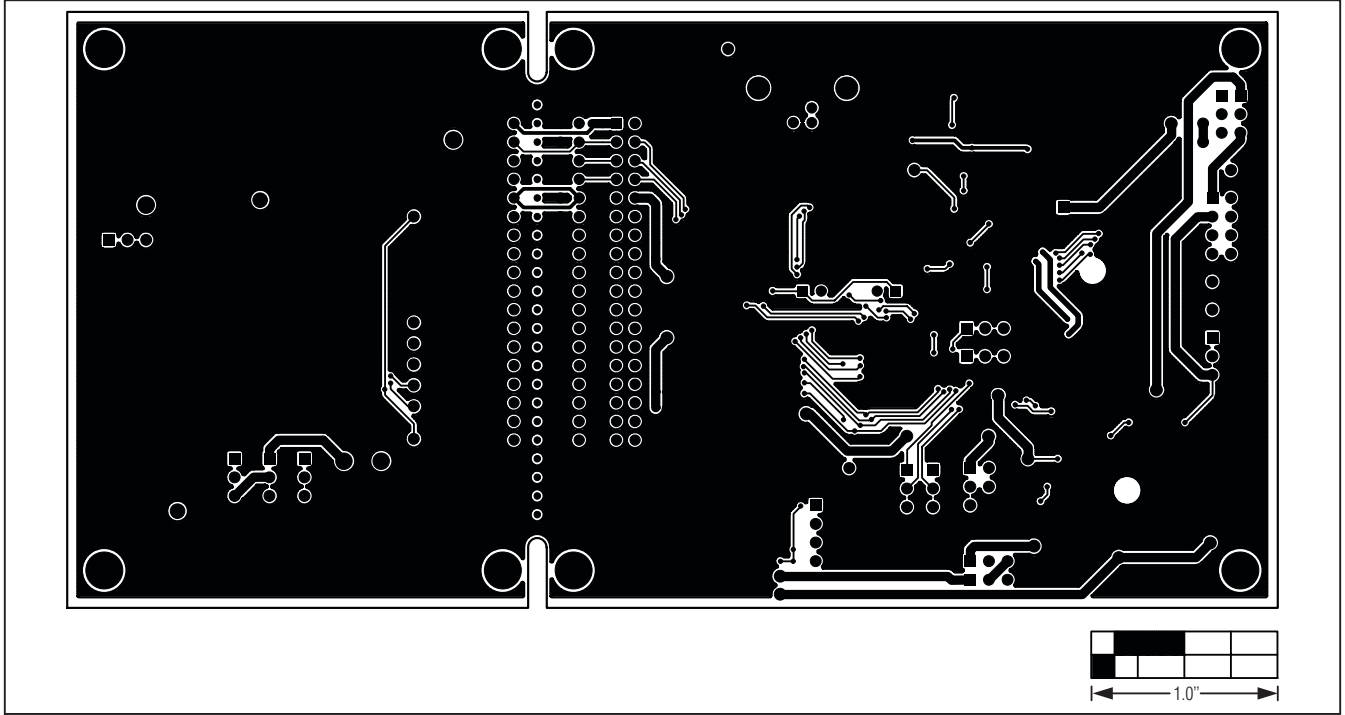

Figure 7. MAX7057 EV Kit PCB Layout—Solder Side

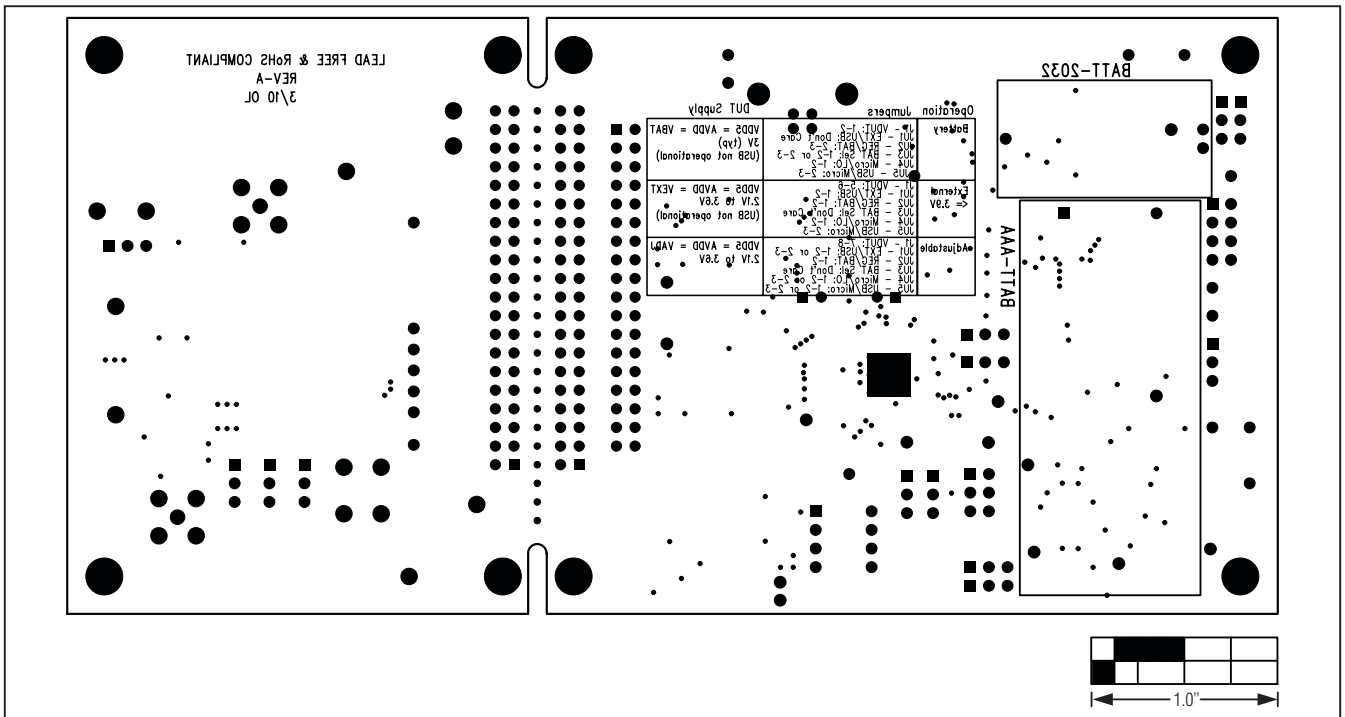

Figure 8. MAX7057 EV Kit Component Placement Guide—Solder Side

MAX7057 Evaluation Kit

Revision History

REVISION NUMBER	REVISION DATE	DESCRIPTION	PAGES CHANGED
0	5/10	Initial release	—

Evaluates: MAX7057

Maxim cannot assume responsibility for use of any circuitry other than circuitry entirely embodied in a Maxim product. No circuit patent licenses are implied. Maxim reserves the right to change the circuitry and specifications without notice at any time.

Maxim Integrated Products, 120 San Gabriel Drive, Sunnyvale, CA 94086 408-737-7600 _____ 19